



Filter Knowledge, Unfiltered

## Technical Service Bulletin 02-1R1

### Coolant Filtration - Products and Compatibility

For over 50 years, the performance of heavy duty cooling systems has been protected and enhanced by the use of coolant filtration and chemical additives. In recent years some new coolant system technologies have been introduced. As with anything new, questions regarding use and compatibility always arise. The following should clarify what is available and how these products should be properly used.

Most heavy-duty diesel engines have wet sleeve cylinder liners, which allow coolant to circulate on the outside of the cylinders to effectively dissipate heat. These wet sleeve liners are susceptible to a failure mechanism known as cavitation erosion if the coolant system is not properly maintained. Cavitation erosion occurs when vapor bubbles, which form due to the rapid side-to-side motion of the liner during the operation of the engine, implode against the outer liner wall. Cavitation erosion can damage liners in as few as 250 hours or 12,000 miles (20,000 km) in engines operated with straight water with no supplemental coolant additive (SCA's). Left untreated, cavitation erosion will eventually erode through the entire liner wall, allowing coolant to enter the lubrication system.

With the proper use of SCA's and filters, you can be assured that your engine is protected from the damages caused by cavitation erosion. If your application is not already equipped with a coolant filter base, installing a remote coolant filter according to the following diagram will allow the use of several different coolant filters depending on the requirements of the application.

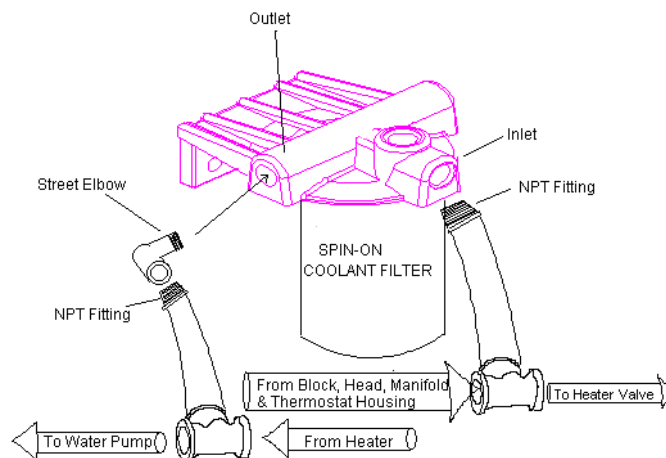

The coolant system products used today can be divided into three basic categories. These categories are based on the recommended service intervals for the various products. Before a particular product is chosen for use, the vehicle or equipment owner or maintenance person must make a decision as to how often they want to perform coolant system maintenance. Once this decision has been made, the appropriate coolant filter, SCA and antifreeze can be placed into service.

The first category can be termed **traditional or standard coolant products**. They can be in the liquid form separate from the filter or a solid form inside a filter. These are the original coolant filtration products that are designed to be used with conventional ethylene or propylene glycol antifreeze. They have a recommended service interval of 10,000-15,000 miles (15,000 – 25,000 km) or 250 hours. It is recommended that a total system flush, re-fill and chemical re-inhibiting of a coolant system using the standard products be done every two years. It is also recommended that a full laboratory coolant analysis be done once a year on these systems.

The second category is a product designed to be in service for 120,000 miles (200,000 km) or 12 months. This chemistry can be referred to as "**need**" or "**slow release**" type. This type of SCA can be in the liquid form or in the solid form inside a filter. The use of the filter version is most popular. This product is designed for use with conventional ethylene or propylene glycol antifreeze. A total system flush, re-fill and re-inhibiting of a coolant system using this product is recommended every two years. It is also recommended that a full laboratory coolant analysis be done once a year on these systems.

The third category can be termed **extended life or long life coolant products**. These are anti-freeze products that contain different inhibitors than those used in supplemental coolant additives. The long life or extended life products contain Organic Acid Technology (OAT) inhibitors. SCA's **are not used** with the extended life or long life anti-freeze products containing OAT inhibitors. The recommended service interval for the extended life or long life products is 150,000 miles (250,000 km) or one year.

From a product compatibility standpoint, filter manufacturers that offer coolant products and SCA's in their product lines have gone to great lengths to make their products totally compatible with others that are in the same category. Caution should be taken to avoid over or under concentration of chemicals if a change is made from one supplier to another. It should also be noted that most coolant product manufacturers offer test strips for quick, in-field testing of the chemical levels in the coolant. These strips are designed to accurately test only that manufacturer's product. They will not accurately test another manufacturer's product.

Finally, if a coolant known as "fully formulated" is used, consumers must find out what exactly is in it. Sometimes it is just water and antifreeze mixed together. To properly use this type of coolant in a heavy duty application, some category of SCA must be used. Other times, fully formulated means water, antifreeze and SCA's are pre-mixed together. Typically this type of fully formulated coolant is an extended life product and no other SCA's need to be added.

Although there are more heavy duty coolant system products available today than ever before, their use is relatively simple as long as each category's design parameters are understood and followed. For further questions regarding coolant products, please contact your filter supplier.

For additional information, contact:

Filter Manufacturers Council  
P.O. Box 13966  
Research Triangle Park, NC 27709-3966  
Phone: 919/549-4800 Fax: 919/406-1306  
[www.filtercouncil.org](http://www.filtercouncil.org)  
Administered by Motor & Equipment Manufacturers Association